

Thermal safety drain Series STS and draught regulator Series RT



Main features

- Thermal safety drain Series STS :
The thermal safety discharge is installed in systems with boilers running on non atomized solid fuel, as protection against over temperature.

- Draught regulator Series RT
The draught regulator is installed in systems with boilers running on non atomized solid fuel, as a control device.

Operation

The heat sensitive element, immersed in the boiler water, expands as temperature increases thus causing the valve plug to open when the temperature reaches the set value.

Maintenance

To ensure correct operation of the thermal safety drain over the long-term, periodic drainage of the valve is required (at least once a year); to perform such operation, press the red discharge button located at the top of the valve head. Such operation allows cleaning the seal seat where foreign particles build up. After a certain number of periodic cleaning operations, it is advisable to replace the valve plug which is supplied as spare part.

Approvals

Approved according to DIN3440 standard, issued by TÜV. It meets the requirements of Body R, point R.3.C.1., 1982 edition, ISPSEL.



STS

SECURFLUX

Thermal safety drain for non atomized, solid fuel boilers with double safety. Nickel-plated brass CW617N body. Immersion probe with 145 mm sheath and 1/2" M connection. Max. drain capacity: 6500 litres/h at 8 bar. Max. operating pressure: 10 bar. Set temperature : 97°C. Max. drain capacity temperature : 107°C

According to TÜV/SVGW.

According to Directive PED 97/23/CE. Identification number CE1115.

Type	Part No.	Size	Capillary
STS	0232120	3/4" F	1300 mm
STS	0232220	3/4" F	2000 mm



STSR

SECURFLUX

Like STS but with just one compact sensitive element. Immersion probe with 108 mm sheath and 3/8" M connection. Max. drain capacity : 3000 litres/h.

Type	Part No.	Size	Capillary
STSR	0232520	3/4" F	1300 mm

Design features	
Body and head	Nickel-plated brass
Seals and O-rings	EPDM rubber
Spring	Stainless steel
Inlet/outlet connections	UNI-ISO228/1 - G3/4" female
Capillary (model STS20 and STS20R)	Length 1300 mm
Capillary (model STS20/200)	Length 2000 mm
Sheath (model STS20 and STS20/200)	1/2" x 145 mm
Sheath (model STS20R)	3/8" x 108 mm

Technical features	
Set temperature	97° C
Max. operating pressure	10 bar
Drain temperature	107° C
Drain capacity (model STS20 and STS20/200)	6500 litres/h at 8 bar
Drain capacity (model STS20R)	3000 litres/h at 8 bar

Installation

The various installation possibilities of the thermal safety drain are illustrated in pictures 1,2,3,4 given alongside:

Pic. 1 - Double combustion boiler system combined with a natural circulation water heater. The system is of the open vessel type (solid fuel) with the thermal safety drain STS installed in the domestic hot water piping at the water heater outlet, before any shut-off device. The sensitive element is fitted in the special well provided on the main boiler. The discharge is conveyed into a siphon. During discharge, the valve draws off hot water from the water heater thus acting as an emergency heat exchanger.

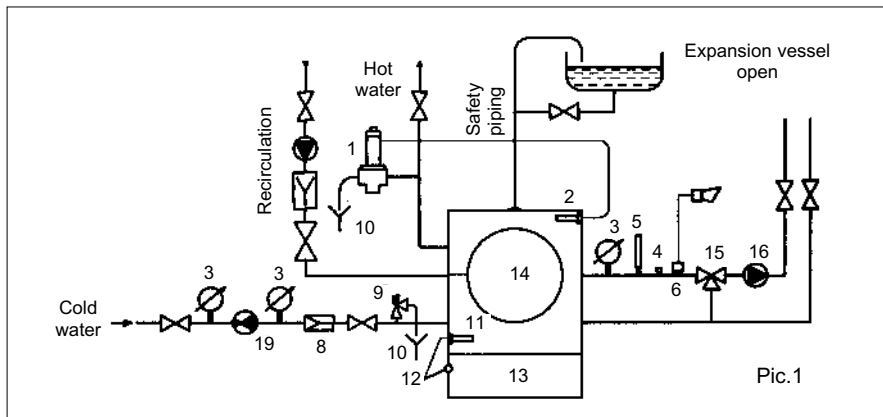

Pic. 2 - System identical to the one in Pic. 1, but without the well for inserting the sensitive element on the boiler. In such case the sensitive element well is installed in the delivery piping, immediately at the boiler outlet, before any shut-off device. Moreover the arrangement features a boiler without expansion connection, hence the safety piping is connected to the delivery line.

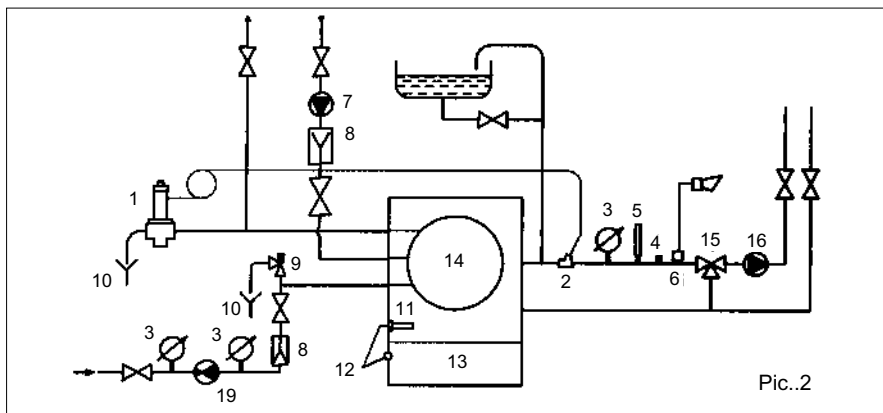

Pic. 3 - Double combustion boiler system combined with a water heater running on forced circulation via a pump. In such case, there is no sense in installing the thermal safety drain on the domestic hot water piping because if the pump stops (fault or power supply failure) the water heater is not able to remove the heat from the boiler for dissipation outside. If the boiler is provided with a built-in emergency heat exchanger, the safety drain should be fitted on the outlet of this heat exchanger; if not, see Pic. 4.

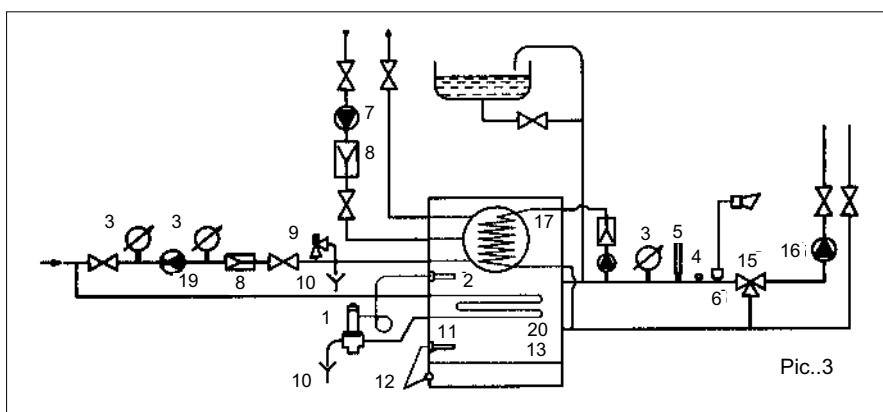

Fig. 4 - Double combustion boiler system without water heater and with emergency heat exchanger connected externally. In such case it is necessary to check whether the entire capacity of the system can be transferred from the boiler to the heat exchanger via natural circulation. As it is difficult to implement such an arrangement, at least in small boilers, it is advisable, in case of doubt, to adopt a thermal drain valve VTF/N installed on the boiler delivery line. In a nutshell, the use of an emergency heater exchanger is only meaningful if it is installed inside the boiler.

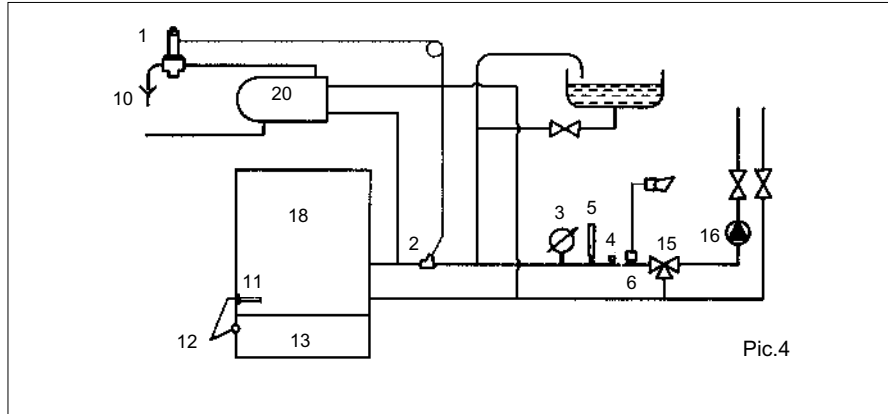
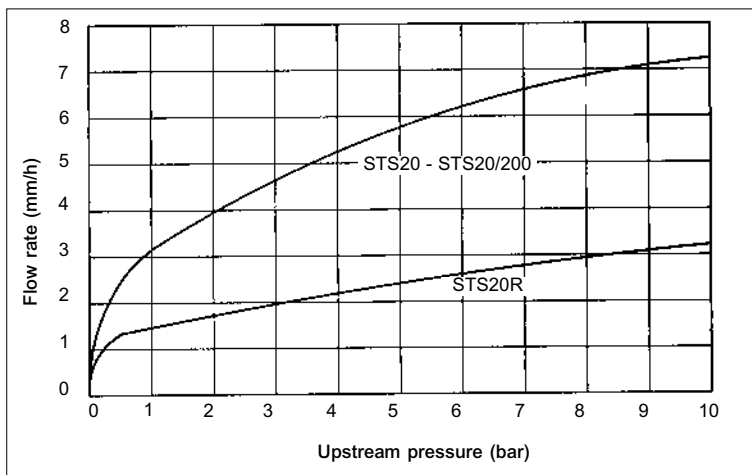
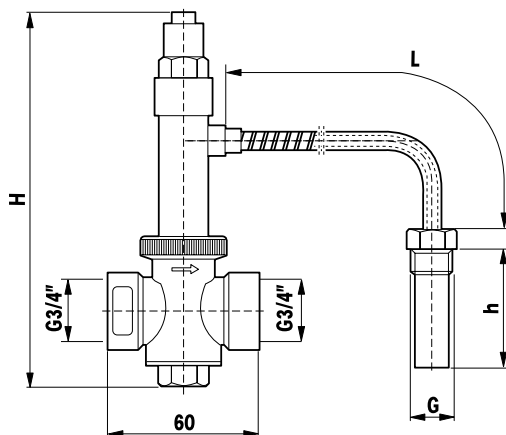

Diagram Upstream pressure – flow rate STS



Overall dimensions (mm)

STS/STSR



Type	G	h	H	L
STS	1/2"	145	133	1300
STS	1/2"	145	133	2000
STSR	3/8"	108	131	1300

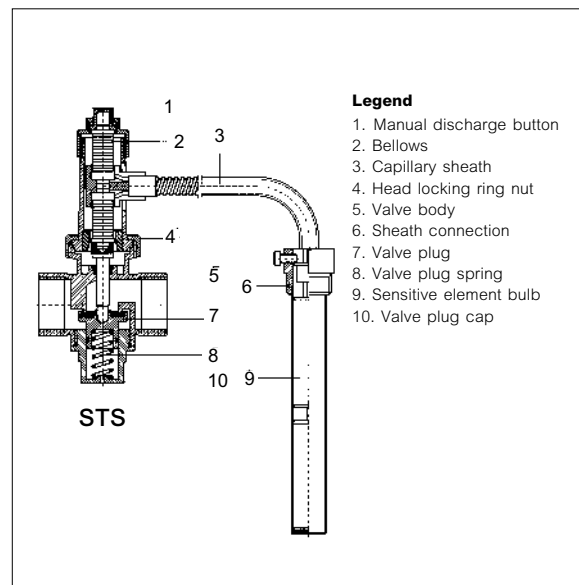

- Legend**
1. Manual discharge button
 2. Bellows
 3. Capillary sheath
 4. Head locking ring nut
 5. Valve body
 6. Sheath connection
 7. Valve plug
 8. Valve plug spring
 9. Sensitive element bulb
 10. Valve plug cap



RT

AIRSTOP

Draught regulator for boilers running on non atomized fuels, with single safety (Item 0234200) or double safety (Item 0234100). Setting range : 40°C to 100°C. Connection ND 3/4". Wax heat sensitive element.

Type	Part No.	Stroke	Chain lenght
RT	0234100	60 mm	125 cm
RT	0234200	80 mm	125 cm

Operation

The draught regulator heat sensitive element, immersed in the boiler water within a sheath, acts on the combustion by appropriately varying introduction of the combustion-supporting air in the boiler in relation to the water temperature. Such regulation is by opening or closing the air inlet door in the boiler.

Approvals

Meets the requirements of Body R, point R.3.C.3, 1982 edition, ISPESEL.

Installation

The draught regulator, **Series RT**, can be installed on the boiler either in horizontal position (front) or in vertical position (upper). For horizontal (front) position, the lever locking screw (12) should be in top position with respect to the draught regulator body (**Pic. 1**) while the temperature should be measured with the red digits. In the horizontal (upper) position, the lever locking screw should be in the rear position with respect to the front of the boiler (**Pic. 2**) while the temperature should be measured with the yellow digits.

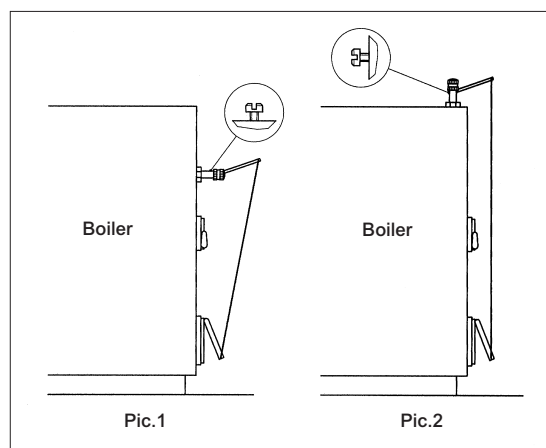

Design features	
Body and sheath	Nickel-plated brass
Adjustment knob	Reinforced plastic
Chain and lever	Tropicalized steel
Connection	UNI-ISO228/1 - G3/4" M
Sheath (model RT20)	3/4" x 75 mm
Sheath (model RT10)	3/4" x 71.5 mm
Heat sensitive element (model RT20)	Two, with wax expansion
Heat sensitive element (model RT10)	One, with wax expansion

Technical features	
Max. water temperature	120° C
Setting range, temperature	40 to 100° C
Max. lever stroke (RT20)	80 mm
Max. lever stroke (RT10)	60 mm

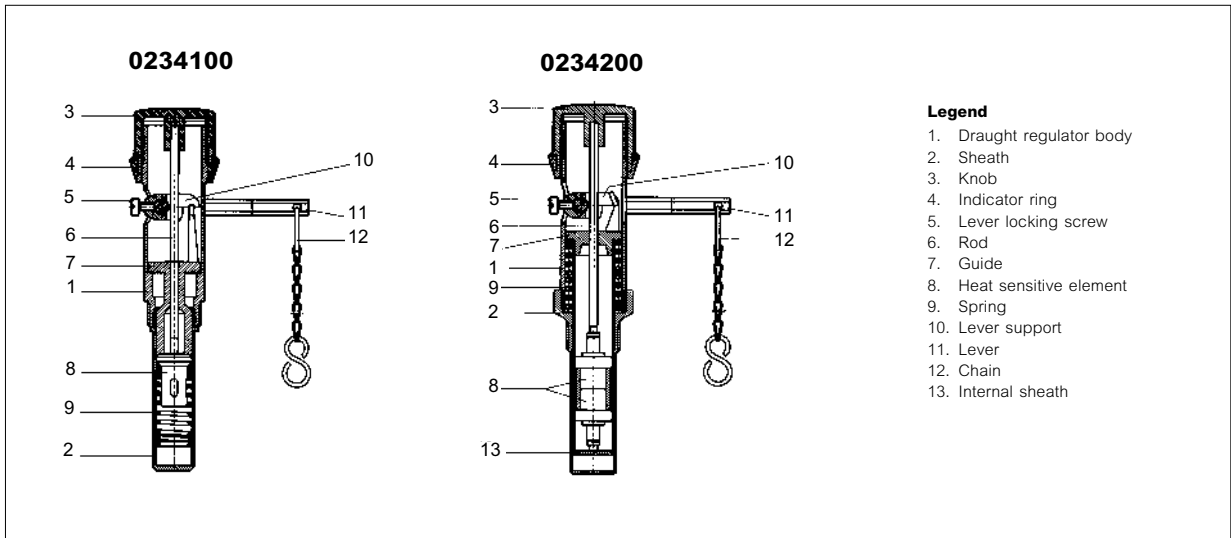

- Legend**
- 1. Draught regulator body
 - 2. Sheath
 - 3. Knob
 - 4. Indicator ring
 - 5. Lever locking screw
 - 6. Rod
 - 7. Guide
 - 8. Heat sensitive element
 - 9. Spring
 - 10. Lever support
 - 11. Lever
 - 12. Chain
 - 13. Internal sheath

Overall dimensions (mm)

RT

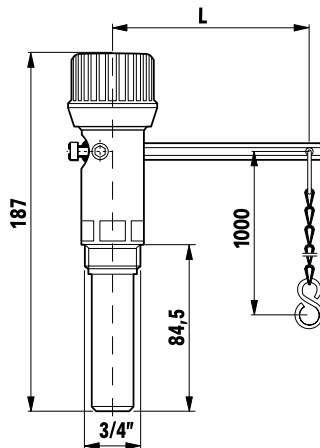

Stroke	L
60	100
80	187,5

The descriptions and photographs contained in this product specification sheet are supplied by way of information only and are not binding. Watts Industries reserves the right to carry out any technical and design improvements to its products without prior notice.



Watts Industries Italia s.r.l.

Via Brenno, 21 - 20046 Biassono (MI), Italy
 Ph. : +39 039 49.86.1 - Fax : +39 039 49.86.222
 e-mail : info@wattsindustries.it
 www.wattsindustries.com